

Miniature Metric Ball Screws

Best-In-Class Load Capacity, Long Life and High Accuracy
For Space-Conscious Applications



Why Choose Thomson Miniature Metric Ball Screws?

Thomson miniature metric ball screw assemblies are precision manufactured to operate efficiently, quietly and smoothly. They deliver best-in-class load capacity while providing ideal solutions for small-footprint applications required in laboratory, robotics and medical markets. Thomson's state-of-the-art production facilities ensure consistent product performance and industry leading delivery.

Better Load Capacity in a Smaller Package

- Design maximizes load capacity by optimizing return system
- Quiet and smooth performance
- Enables flexible ball nut mounting configurations and rapid prototyping

Improved Value

- Precision screws to $\pm 52 \mu\text{m}/300 \text{ mm}$ (T7) accuracy class standard
- State-of-the-art manufacturing provides lower cost and improved performance
- Higher load capacity equates to longer life

Genuine Thomson Quality and Innovation

- Proprietary thread form and processing equal superior quality and performance
- Expert technical and application support

Optimized Ball Nut Design

The challenge for Thomson's engineers was to optimize the design of the ball nut. The solution was the unique multi-liner return system that provides smoother operation and, as illustrated in the example below, more load capacity.

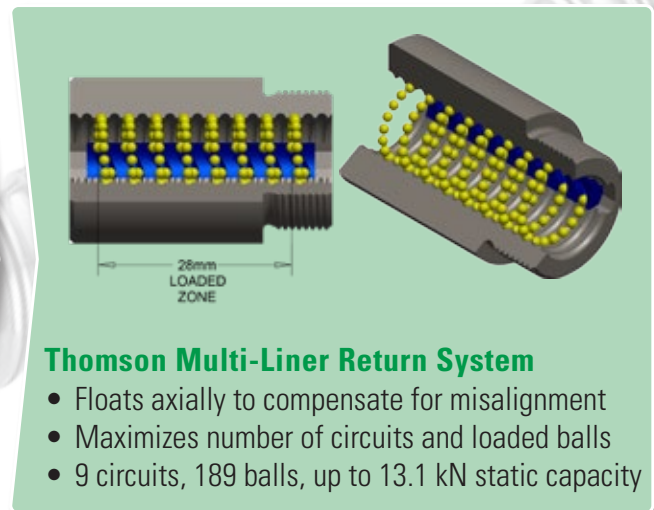
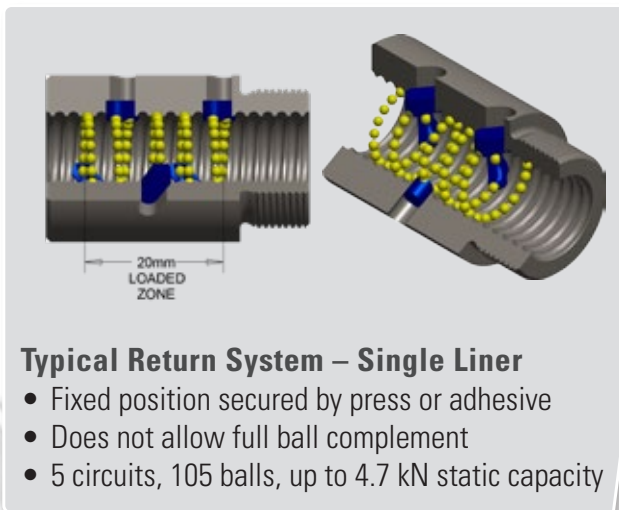

MINI. STRONG. PRECISE.

Product Overview

Standard Configuration

- Screw diameters from 8 to 12 mm
- Screw lengths up to 3,000 mm
- Ball nuts with threaded, flanged or cylindrical mounting interface
- Carbon steel construction
- Internal ball return system
- Performance repeatability (0.05 mm backlash)

Optional Configurations

- Thin dense chrome coating
- Black oxide coating
- Ball nut without wipers
- +/- 12 µm/300 mm lead accuracy (P3)
- +/- 23 µm/300 mm lead accuracy (P5)
- Preload options

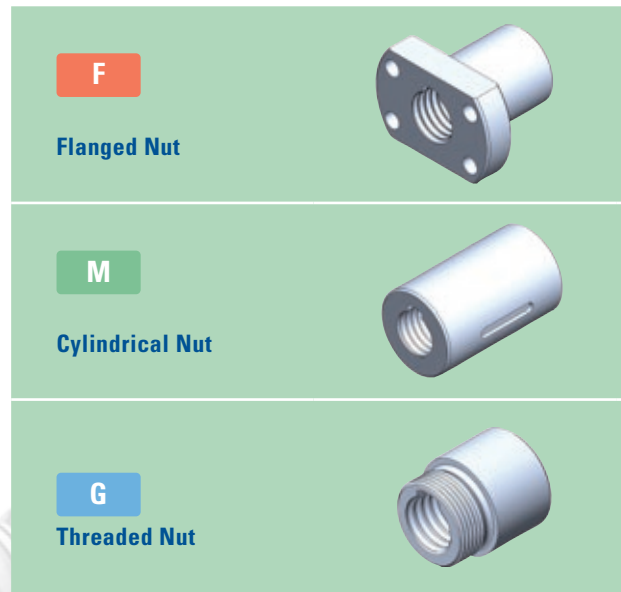

Ordering Key

Miniature Metric Ball Screw/Nut Assembly																													
1	2	3	4	5	6	7	8	9	10	11	12	13	14	15	16	17													
KGT	-	D	-	10	02	-	T7	-	RH	-	K	18	-	143	-	K	4	-	F	-	M	-	EE	-	R	-	0	-	0
1. Ball Screw Assembly KGT = Metric Ball Screw Assembly				5. Lead Accuracy P3 = 12 µm / 300 mm P5 = 23 µm / 300 mm T7 = 52 µm / 300 mm				10. Screw End 2 X = Cut to length K = Machine to print				15. Manufacturing Process R = Rolled G = Ground																	
2. Nut Version D = According to DIN 69051 G = Cylindrical Threaded				6. Thread Direction RH = Right hand thread				11. Length End 2 [mm] for X/K end 2				16. Special Version or with Accessories 0 = No 1 = Yes (per customer specification)																	
3. Nominal Diameter 08 = 8 mm 10 = 10 mm 12 = 12 mm				7. Screw End 1 X = Cut to length K = Machine to print				12. Nut Style F = Flanged M = Cylindrical G = Threaded				17. Backlash / Preload Options 0 = Normal 1 = Backlash reduced 2 = Light preload (1-3%) 3 = Preload (>4%)																	
4. Threaded Lead 02 = 2 mm 025 = 2.5 mm 03 = 3 mm 05 = 5 mm				8. Length End 1 [mm] for X/K end 1				13. Return System M = Multi Liner K = Channel				14. Wipers EE = Rubber KK = Polymer 00 = No Wiper																	
				9. Overall Screw Length [mm]																									



Miniature Metric Ball Screw Assemblies – General Specifications

Features and Benefits



Product Availability				
Diameter [mm]	Lead [mm]			
	2	2.5	3	5
8		●		●
10	●		●	
12	●			

- Precision screws
- Screw diameters from 8 to 12 mm
- Thomson Return System
- Cost-effective and space-saving solution
- Flexible solution for non-standard mounting
- Integrated wipers and lube port

Performance Specifications									
Nominal Diameter	Lead	Ball Screw P/N	Screw Material	Performance Data					
				Modified Dynamic Load Rating ⁽¹⁾ (C _{dm})		Modified Static Load Rating* (C _{0dm})		Max. Axial Backlash	Standard Lead Accuracy
				[kN]	[lbf]	[kN]	[lbf]		
8	2.5	1905000104	AISI 1566	2.1	472	2.2	494	0.05	± 23
8	5	1905000704	AISI 1566	2.5	562	2.8	629		± 23
10	2	0205000378	CF53	3.7	831	4.6	1034		± 52
10	3	0205000379	CF53	5.2	1169	6.9	1551		± 52
12	2	0205000380	CF53	5.9	1326	8.9	2000		± 52

(1) Based on 1 million revolutions.

* Load rating calculations comply with ISO 3408-5.

Dimensional Screw and Nut Specifications									
Nominal Diameter	Lead	Screw Specifications						Nut Specifications	
		Major Diameter		Minor Diameter		Max. Length	Weight	Number of Circuits	Ball Diameter
		[mm]	[in]	[mm]	[in]	[mm]	[kg/m]		[mm]
8	2.5	8.0	0.315	6.83	0.269	280	0.39	3	1.588
8	5	8.0	0.315	6.83	0.269	280	0.39	2.8	1.588
10	2	9.8	0.386	8.3	0.328	3000	0.59	4	1.588
10	3	9.7	0.383	8.0	0.313	3000	0.58	6	1.588
12	2	11.8	0.465	10.3	0.407	3000	0.86	6	1.588

Miniature Metric Ball Nuts – Technical Specifications

F Flanged Nut

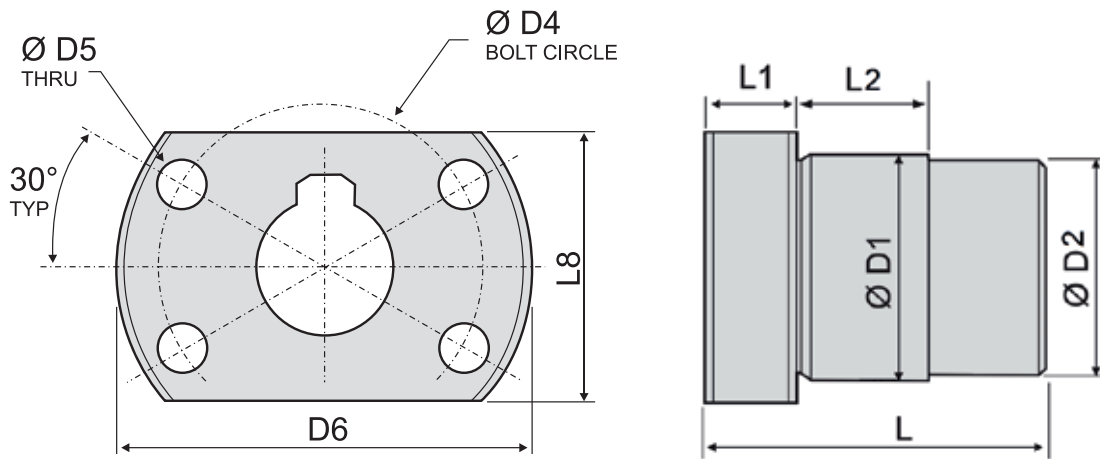

Dimensional Specifications												
Nominal Diameter	Lead	Ball Nut Length (L)	Ball Nut P/N	Nut Material	Dimensions*							
					D1 (g6)	D2	D4	D5	D6	L1	L2	L8
[mm]	[mm]	[mm]			[mm]	[mm]	[mm]	[mm]	[mm]	[mm]	[mm]	[mm]
8	2.5	18	0215200422	ESP 65	16	15.8	22	3.4	28	6	7	19
8	5	23	0215200424	ESP 65	16	15.8	22	3.4	28	6	10	19
10	2	24	0215200427	ESP 65	19	18.8	28	4.5	36	6	10	23
10	3	29	0215200420	ESP 65	19	18.8	28	4.5	36	6	10	23
12	2	34	0215200418	ESP 65	24	23.8	32	4.5	40	8	10	26

* Flange dimensions comply with ISO 3408-2.



Miniature Metric Ball Nuts – Technical Specifications

M Cylindrical Nut

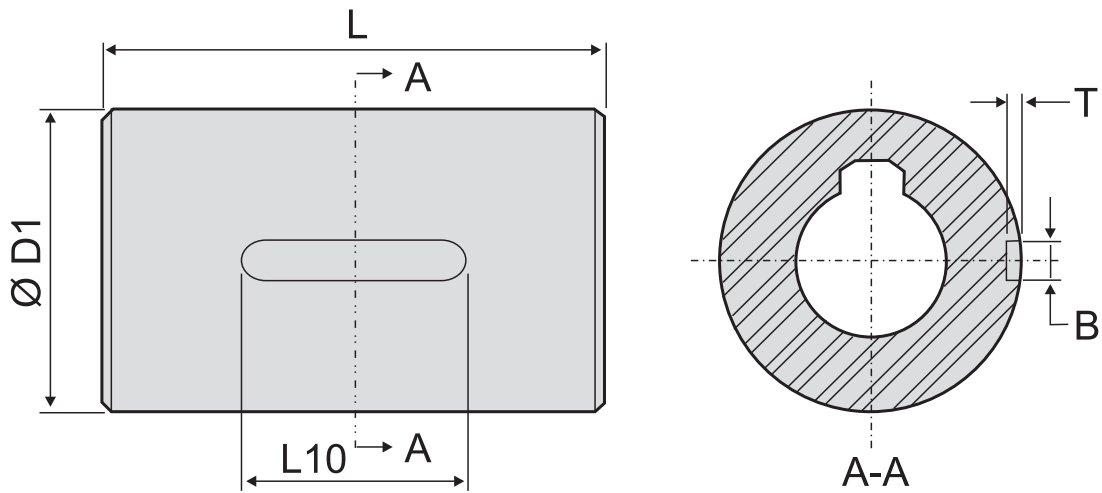

Dimensional Specifications

Nominal Diameter	Lead	Ball Nut Length (L)	Ball Nut P/N	Nut Material	Dimensions		
					D1 (g6)	B × T (P9)	L10
[mm]	[mm]	[mm]			[mm]	[mm]	[mm]
8	2.5	18	0215050409	ESP 65	16	3 × 2	8
8	5	23	0215050413	ESP 65	16	3 × 2	8
10	2	24	0215050401	ESP 65	19	3 × 2	10
10	3	29	0215050405	ESP 65	19	3 × 2	13
12	2	34	0215050397	ESP 65	24	3 × 2	18

Miniature Metric Ball Nuts – Technical Specifications

G Threaded Nut

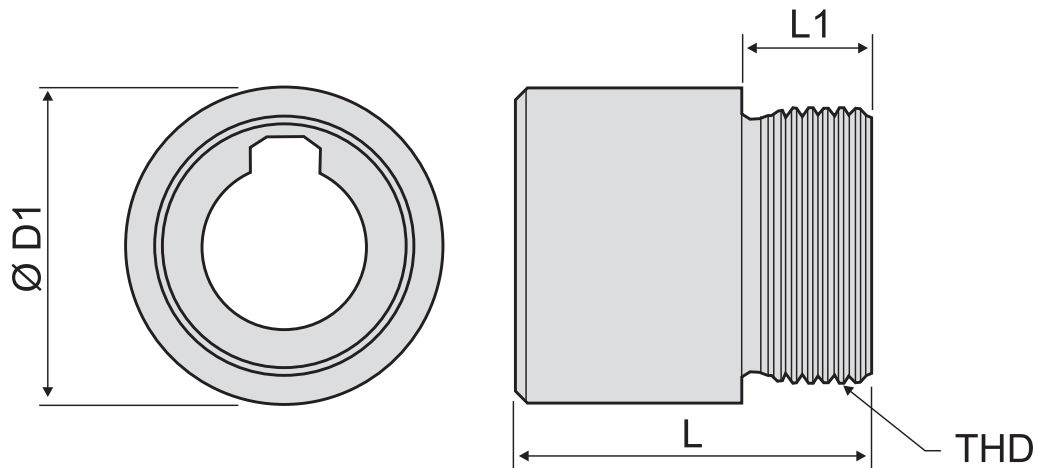

Dimensional Specifications							
Nominal Diameter	Lead	Ball Nut Length (L)	Ball Nut P/N	Nut Material	Dimensions		
					D1 (h12)	THD	L1
[mm]	[mm]	[mm]					[mm]
8	2.5	18	0215050411 ⁽¹⁾	ESP 65	16	M15 x 1	8
10	2	24	0215050403	ESP 65	19	M17 x 1	8
10	3	29	0215050407	ESP 65	19	M18 x 1	9
12	2	34	0215050399	ESP 65	24	M20 x 1	10

(1) No wiper option available.

Contact us or any of our 2000+ global distribution partners by scanning the code below
or visiting www.thomsonlinear.com/contact



RegalRexnord™

www.regalrexnord.com

www.thomsonlinear.com

Miniature_Metric_Ball_Screws_BRUK-0009-08 | 20260417SK | MCB-12714-TL-EN-A4 04/26
Specifications are subject to change without notice. It is the responsibility of the product user to
determine the suitability of this product for a specific application. All trademarks property of their
respective owners. ©2026 Thomson Industries, Inc. | 2400 Curtiss Street, Downers Grove, IL 60515 USA

THOMSON®