

500 Series Profile Rail Enhanced Carriage

New, 66% Smoother Running Design, with 50% Lower Drag Force*

New Stainless Steel Options

Features and Benefits

Now available in sizes 15 and 35: the new Thomson 500 Series Profile Rail enhanced carriage design can improve the smoothness and precision of your linear motion application. New optional 440B stainless steel carriages and rails provide corrosion resistance well-suited for medical, food, electronic assembly and semiconductor applications.

- New, smoother running design optimizes the surface interfaces between steel and plastic transition areas along the ball bearing circulation path.
- New standard end seals provide twice the contaminant protection compared to competitive products. Optional low drag end seals are ideal for low pushforce requirements.
- Four longitudinal seals per carriage provide much better contaminant protection than competitive designs with only two longitudinal seals.
- Additional lubrication reservoir enables longer running time and easy change end caps & seals are quick to replace.
- 100% interchangeable with previous Thomson 500 Series carriage and rail.
- New design is a running change that replaces the previous Thomson 500 Series design, starting with sizes 15 and 35. **Coming soon: sizes 20, 25, 30, and 45.**

* 66% smoothness increase measured as variability of drag force while the carriage is in motion. 50% lower drag force measured with new low drag seals option; 41% lower drag force measured with standard wiper option.

For Immediate assistance
E-mail: contactus@danahermotion.com
Tel. North America: +1-540-633-3400
www.danahermotion.com



Danaher Motion offers six carriage styles with six mounting holes allowing for additional mounting configurations in the field or for retrofitting. All provide superior rigidity and design flexibility.

500 Series Ball Standard Carriages

Standard Carriage Style A

| Size | Accuracy | Basic Part Number | | | | Appropriate Rail Standard Style | Max. Single Piece Rail Length (mm) |
|------|----------|-------------------|----------|----------|----------|---------------------------------|------------------------------------|
| | | Clearance | Preload | | | | |
| | | | 0.03C | 0.08C | 0.13C | | |
| 15 | H | 511H15A0 | 511H15A1 | 511H15A2 | — | 521H15A | 1500 |
| | P | — | 511P15A1 | 511P15A2 | 511P15A3 | 521P15A | |
| | U | — | 511U15A1 | 511U15A2 | 511U15A3 | 521U15A | |
| 35 | H | 511H35A0 | 511H35A1 | 511H35A2 | — | 521H35A | 6000 |
| | P | — | 511P35A1 | 511P35A2 | 511P35A3 | 521H35A | |
| | U | — | 511U35A1 | 511U35A2 | 511U35A3 | 521H35A | |

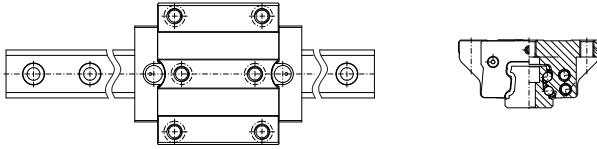

Standard Carriage Style B

| Size | Accuracy | Basic Part Number | | | | Appropriate Rail Standard Style | Max. Single Piece Rail Length (mm) |
|------|----------|-------------------|----------|----------|----------|---------------------------------|------------------------------------|
| | | Clearance | Preload | | | | |
| | | | 0.03C | 0.08C | 0.13C | | |
| 35 | H | 511H35B0 | 511H35B1 | 511H35B2 | — | 521H35A | 6000 |
| | P | — | 511P35B1 | 511P35B2 | 511P35B3 | 521P35A | |
| | U | — | 511U35B1 | 511U35B2 | 511U35B3 | 521U35A | |

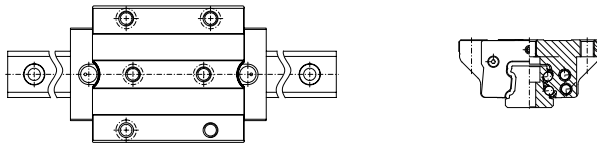

Standard Carriage Style C

| Size | Accuracy | Basic Part Number | | | | Appropriate Rail Standard Style | Max. Single Piece Rail Length (mm) |
|------|----------|-------------------|----------|----------|----------|---------------------------------|------------------------------------|
| | | Clearance | Preload | | | | |
| | | | 0.03C | 0.08C | 0.13C | | |
| 15 | H | 511H15C0 | 511H15C1 | 511H15C2 | — | 521H15A | 1500 |
| | P | — | 511P15C1 | 511P15C2 | 511P15C3 | 521P15A | |
| | U | — | 511U15C1 | 511U15C2 | 511U15C3 | 521U15A | |
| 35 | H | 511H35C0 | 511H35C1 | 511H35C2 | — | 521H35A | 6000 |
| | P | — | 511P35C1 | 511P35C2 | 511P35C3 | 521P35A | |
| | U | — | 511U35C1 | 511U35C2 | 511U35C3 | 521U35A | |

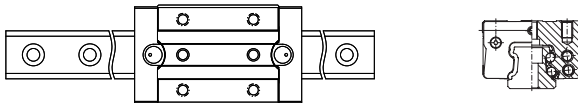

Standard Carriage Style D

| Size | Accuracy | Basic Part Number | | | | Appropriate Rail Standard Style | Max. Single Piece Rail Length (mm) |
|------|----------|-------------------|----------|----------|----------|---------------------------------|------------------------------------|
| | | Clearance | Preload | | | | |
| | | | 0.03C | 0.08C | 0.13C | | |
| 35 | H | 511H35D0 | 511H35D1 | 511H35D2 | — | 521H35A | 6000 |
| | P | — | 511P35D1 | 511P35D2 | 511P35D3 | 521P35A | |
| | U | — | 511U35D1 | 511U35D2 | 511U35D3 | 521U35A | |

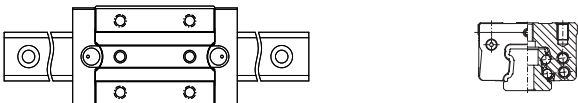

COMING SOON
Sizes 20, 25, 30 & 45

500 Series Ball Standard Carriages

Standard Carriage Style E

| Size | Accuracy | Basic Part Number | | | | Appropriate Rail Standard Style | Max. Single Piece Rail Length (mm) |
|------|----------|-------------------|----------|----------|----------|---------------------------------|------------------------------------|
| | | Clearance | Preload | | | | |
| | | | 0.03C | 0.08C | 0.13C | | |
| 15 | H | 511H15E0 | 511H15E1 | 511H15E2 | — | 521H15A | 1500 |
| | P | — | 511P15E1 | 511P15E2 | 511P15E3 | 521P15A | |
| | U | — | 511U15E1 | 511U15E2 | 511U15E3 | 521U15A | |
| 35 | H | 511H35E0 | 511H35E1 | 511H35E2 | — | 521H35A | 6000 |
| | P | — | 511P35E1 | 511P35E2 | 511P35E3 | 521P35A | |
| | U | — | 511U35E1 | 511U35E2 | 511U35E3 | 521U35A | |

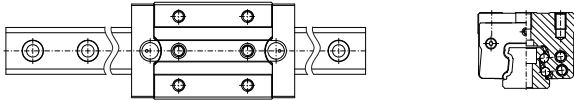

Standard Carriage Style F

| Size | Accuracy | Basic Part Number | | | | Appropriate Rail Standard Style | Max. Single Piece Rail Length (mm) |
|------|----------|-------------------|----------|----------|----------|---------------------------------|------------------------------------|
| | | Clearance | Preload | | | | |
| | | | 0.03C | 0.08C | 0.13C | | |
| 35 | H | 511H35F0 | 511H35F1 | 511H35F2 | — | 521H35A | 6000 |
| | P | — | 511P35F1 | 511P35F2 | 511P35F3 | 521P35A | |
| | U | — | 511U35F1 | 511U35F2 | 511U35F3 | 521U35A | |

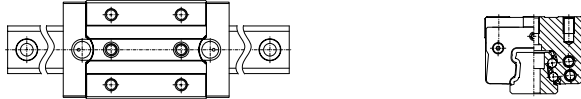

Standard Carriage Style G

| Size | Accuracy | Basic Part Number | | | | Appropriate Rail Standard Style | Max. Single Piece Rail Length (mm) |
|------|----------|-------------------|----------|----------|----------|---------------------------------|------------------------------------|
| | | Clearance | Preload | | | | |
| | | | 0.03C | 0.08C | 0.13C | | |
| 15 | H | 511H15G0 | 511H15G1 | 511H15G2 | — | 521H15A | 1500 |
| | P | — | 511P15G1 | 511P15G2 | 511P15G3 | 521P15A | |
| | U | — | 511U15G1 | 511U15G2 | 511U15G3 | 521U15A | |

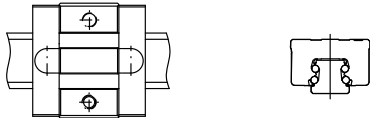

COMING SOON
 Sizes 20, 25, 30 & 45

500 Series Ball
511 Style A and B

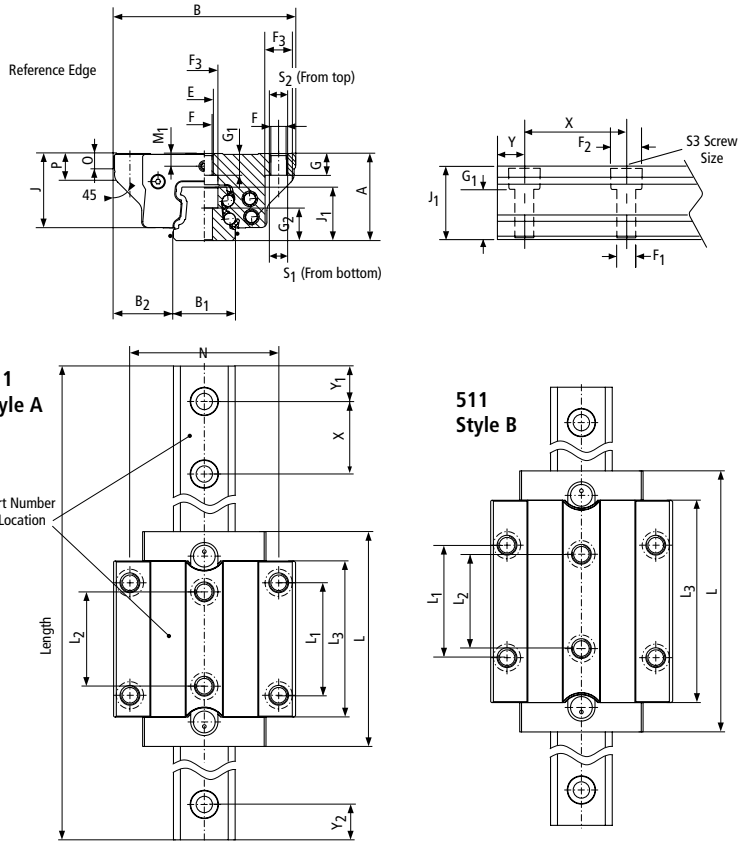
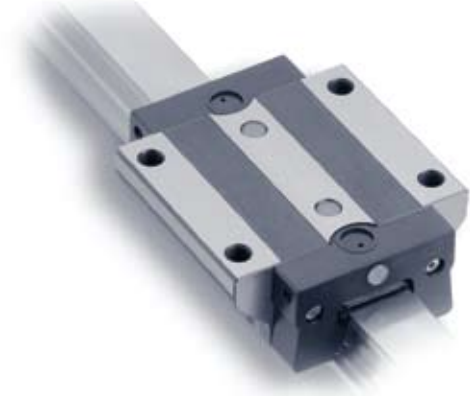

511 Style A - Standard Ball

| Size | Dimensions (mm) | | | | | | L | L ₁ | L ₂ | L ₃ | X | N | S ₁ | S ₂ | S ₃ | F | F ₁ | F ₂ | F ₃ | Ball | | | | | | |
|------|-----------------|-----|----------------|----------------|------|----------------|-------|----------------|----------------|----------------|----|----|----------------|----------------|----------------|-----|----------------|----------------|----------------|------|----|----------------|----------------|----------------|---|----|
| | A | B | B ₁ | B ₂ | J | J ₁ | | | | | | | | | | | | | | Ø | G | G ₁ | G ₂ | M ₁ | O | P |
| 15 | 24 | 47 | 15 | 16 | 20.2 | 15.7 | 56.6 | 30 | 26 | 39.6 | 60 | 38 | M5 | M5 | M4 | 4.4 | 4.5 | 8 | 7.5 | 3.2 | 7 | 4.5 | 9.5 | 4 | 7 | 7 |
| 35 | 48 | 100 | 34 | 33 | 41 | 29.5 | 111.6 | 62 | 52 | 79.6 | 80 | 82 | M10 | M10 | M8 | 8.5 | 9 | 15 | 15 | 6.4 | 12 | 12 | 18 | 7 | 8 | 14 |

511 Style B - Standard Long Ball

| Size | Dimensions (mm) | | | | | | L | L ₁ | L ₂ | L ₃ | X | N | S ₁ | S ₂ | S ₃ | F | F ₁ | F ₂ | F ₃ | Ball | | | | | | |
|------|-----------------|-----|----------------|----------------|----|----------------|-------|----------------|----------------|----------------|----|----|----------------|----------------|----------------|-----|----------------|----------------|----------------|------|----|----------------|----------------|----------------|---|----|
| | A | B | B ₁ | B ₂ | J | J ₁ | | | | | | | | | | | | | | Ø | G | G ₁ | G ₂ | M ₁ | O | P |
| 35 | 48 | 100 | 34 | 33 | 41 | 29.5 | 137.1 | 62 | 52 | 105.1 | 80 | 82 | M10 | M10 | M8 | 8.5 | 9 | 15 | 15 | 6.4 | 12 | 12 | 18 | 7 | 8 | 14 |



COMING SOON
Sizes 20, 25, 30 & 45

**500 Series Ball
511 Style C and D**

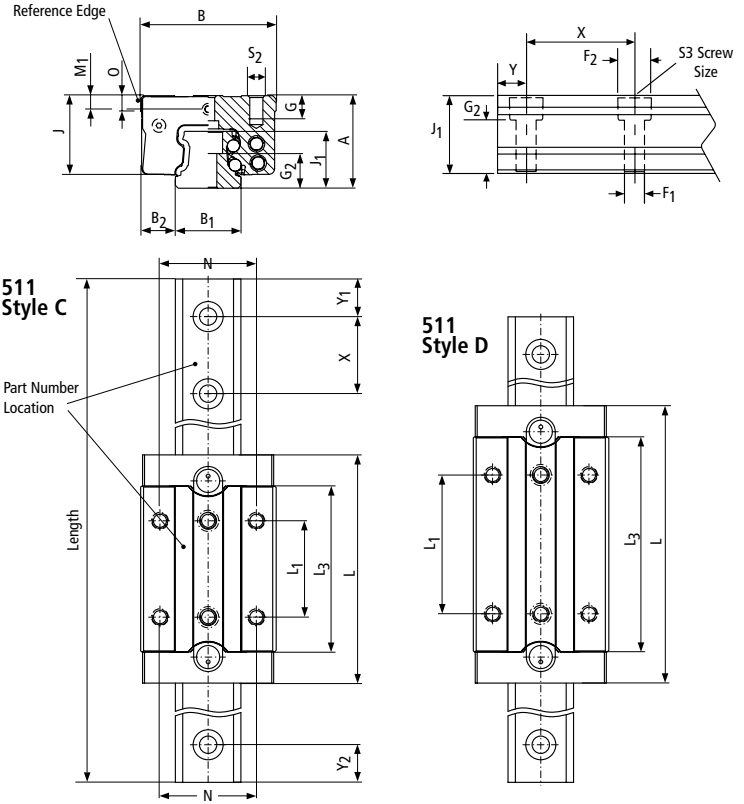

511 Style C - Narrow

| Size | Dimensions (mm) | | | B ₂ | J | J ₁ | L | L ₁ | L ₃ | X | N | S ₂ / S ₃ | F ₁ | F ₂ | Ball | | | | |
|------|-----------------|-------------------|-------------------------|----------------|------|----------------|-------|----------------|----------------|----|----|---------------------------------|----------------|----------------|------|----|----------------|----------------|---|
| | A | B +0.4 -0.0 | B ₁ ±0.05 | | | | | | | | | | | | Ø | G | G ₂ | M ₁ | O |
| 15 | 24 | 34 | 15 | 9.5 | 20.2 | 15.7 | 59.8 | 26 | 42.8 | 60 | 26 | M4 | 4.5 | 8 | 3.2 | 5 | 9.5 | 4 | 7 |
| 35 | 48 | 70 | 34 | 18 | 41 | 29.5 | 111.6 | 50 | 79.6 | 80 | 50 | M8 | 9 | 15 | 6.4 | 12 | 18 | 7 | 8 |

511 Style D - Narrow Long

| Size | Dimensions (mm) | | | B ₂ | J | J ₁ | L | L ₁ | L ₃ | X | N | S ₂ / S ₃ | F ₁ | F ₂ | Ball | | | | |
|------|-----------------|-------------------|-------------------------|----------------|----|----------------|-------|----------------|----------------|----|----|---------------------------------|----------------|----------------|------|----|----------------|----------------|---|
| | A | B +0.4 -0.0 | B ₁ ±0.05 | | | | | | | | | | | | Ø | G | G ₂ | M ₁ | O |
| 35 | 48 | 70 | 34 | 18 | 41 | 29.5 | 143.5 | 72 | 111.5 | 80 | 50 | M8 | 9 | 15 | 6.4 | 12 | 18 | 7 | 8 |



COMING SOON
Sizes 20, 25, 30 & 45

500 Series Ball
511 Style E and F

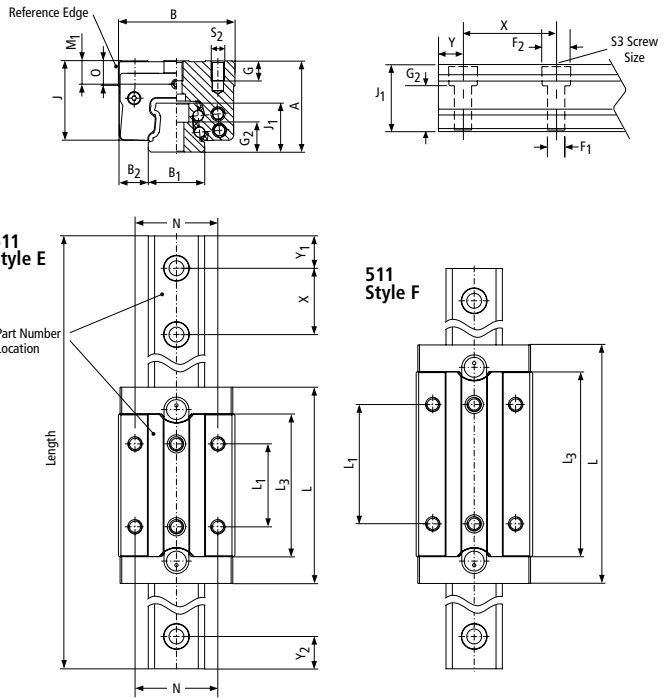

511 Style E - Narrow High

| Size | Dimensions (mm) | | | B ₂ | J | J ₁ | L | L ₁ | L ₃ | X | N | S ₂ / S ₃ | F ₁ | F ₂ | Ball Ø | G | G ₂ | M ₁ | O |
|------|-----------------|--------------|----------------|----------------|------|----------------|-------|----------------|----------------|----|----|---------------------------------|----------------|----------------|--------|----|----------------|----------------|----|
| | A | B | B ₁ | | | | | | | | | | | | | | | | |
| | | +0.4 -0.0 | ±0.05 | | | | | | | | | | | | | | | | |
| 15 | 28 | 34 | 15 | 9.5 | 24.2 | 15.7 | 59.8 | 26 | 42.8 | 60 | 26 | M4 | 4.5 | 8 | 3.2 | 6 | 9.5 | 8 | 6 |
| 35 | 55 | 70 | 34 | 18 | 48 | 29.5 | 111.6 | 50 | 79.6 | 80 | 50 | M8 | 9 | 15 | 6.4 | 12 | 18 | 14 | 15 |

511 Style F - Narrow Long High

| Size | Dimensions (mm) | | | B ₂ | J | J ₁ | L | L ₁ | L ₃ | X | N | S ₂ / S ₃ | F ₁ | F ₂ | Ball Ø | G | G ₂ | M ₁ | O |
|------|-----------------|--------------|----------------|----------------|----|----------------|-------|----------------|----------------|----|----|---------------------------------|----------------|----------------|--------|----|----------------|----------------|----|
| | A | B | B ₁ | | | | | | | | | | | | | | | | |
| | | +0.4 -0.0 | ±0.05 | | | | | | | | | | | | | | | | |
| 35 | 55 | 70 | 34 | 18 | 48 | 29.5 | 143.5 | 72 | 111.5 | 80 | 50 | M8 | 9 | 15 | 6.4 | 12 | 18 | 14 | 15 |

511 Style G

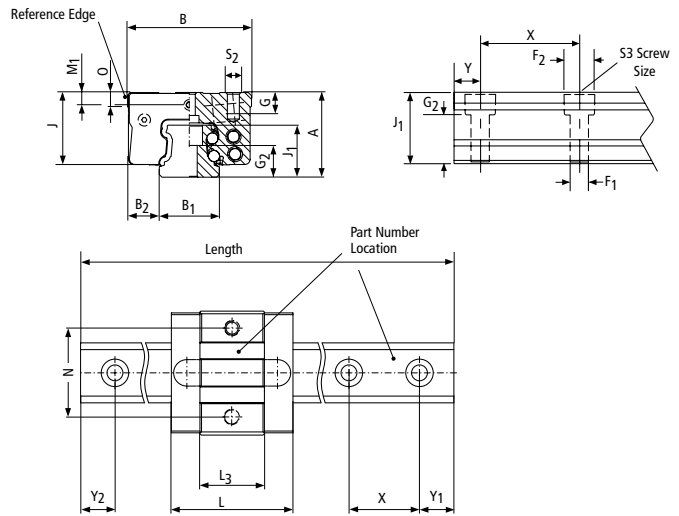
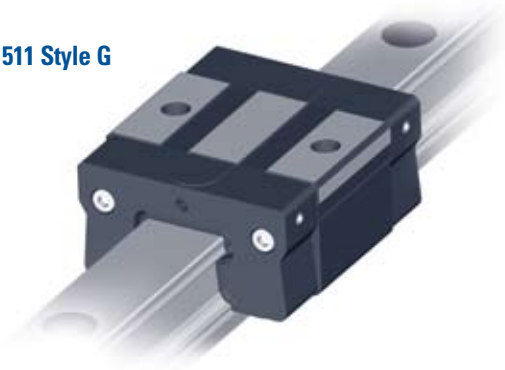

511 Style G - Narrow Short

| Size | Dimensions (mm) | | | B ₂ | J | J ₁ | L | L ₃ | X | N | S ₂ / S ₃ | F ₁ | F ₂ | Ball Ø | G | G ₂ | M ₁ | O |
|------|-----------------|--------------|------------------|----------------|------|----------------|------|----------------|----|----|---------------------------------|----------------|----------------|--------|---|----------------|----------------|---|
| | A | B | B ₁ * | | | | | | | | | | | | | | | |
| | | +0.4 -0.0 | ±0.05 | | | | | | | | | | | | | | | |
| 15 | 24 | 34 | 15 | 9.5 | 20.2 | 15.7 | 37.6 | 20.6 | 60 | 26 | M4 | 4.5 | 8 | 3.2 | 6 | 9.5 | 4 | 6 |
| 35 | 24 | 34 | 15 | 9.5 | 20.2 | 15.7 | 37.6 | 20.6 | 60 | 26 | M4 | 4.5 | 8 | 3.2 | 6 | 9.5 | 4 | 6 |

